

AIRMAN® also provides you with the following products

Engine Generator

Standard / Leak-guard / Ultra super silent type
Prime output: 10.5 - 800 kVA



Motor Compressor

Oil injection / Oil free / Indoor / Outdoor type
Rated output: 3.7 - 200 kW



Scissors Lifter

Self-propelled / Hand push type
Max. height above ground: 3.2 - 9.9 m



Mini-Excavator

Zero-tail swing type
Operating weight: 1,110 - 5,210 kg



Portable Diesel Screw
ENGINE COMPRESSORS



AIRMAN CORPORATION

8th Floor Shinjuku San-Ei Bldg,
22-2 Nishi-Shinjuku 1-Chome, Shinjuku-ku,
Tokyo 160-0023 Japan
Tel: 81-3-3348-7281 Fax: 81-3-3348-7289
E-mail: airman.oversea@airman.co.jp
<https://www.airman.co.jp>

AIRMAN ASIA SDN. BHD.

Suite A-8-2, level 8, Block A, Sky Park @ One City,
Jalan USJ 25/1, 47650 Subang Jaya, Selangor, Malaysia
Tel: 60-3-5036-7228 Fax: 60-3-5036-7226
E-mail: sales@airman-asia.com
<https://airman-asia.com>

HOKUETSU INDUSTRIES EUROPE B.V.

Aalsmeerderdijk 156, 1438 AX Oude Meer, The Netherlands
Tel: 31-20-6462636 Fax: 31-20-6462191
E-mail: info@hokuetsu.nl
<https://www.hokuetsu.eu>

AIRMAN USA CORPORATION

95 International PKWY, Suite 100, Adairsville, GA 30103
Tel: 1-678-800-7070 Fax: 1-770-769-4335
<https://airman-usa.com>

OUR HEAD OFFICE AND PLANT ARE CERTIFIED TO BOTH ISO 9001 AND ISO 14001.

Niigata plant:
Shimo Aozu, Tsubame-city, Niigata-prefecture, Japan.



ISO9001 : JQA-0581
ISO14001 : JQA-EM4670



DISTRIBUTOR :

AIRMAN DRIVES A NEW BREEZE OF INNOVATION

Since 1938, we have built over eight decades of expertise in compressor engineering, manufacturing, sales, and after-sales support. By controlling every stage in-house, we deliver uncompromising quality and long-term reliability.

As a comprehensive industrial machinery manufacturer, AIRMAN pioneers innovative, industry-defining solutions trusted worldwide.



CHALLENGE TO THE NEW ERA

01

High-efficiency rotors achieve large air volume

AS rotors (highly-efficient rotors) enable the device to efficiently produce high-level volumes of air. High efficiency AS rotors enable to produce the class-leading air volume.

02

Excellent operability

Digital monitor panels and touch screen panel are provided for visibility, while the pressure gauge is equipped with an analog meter that is easy to understand.



Touch screen panel

※Image is for illustration purposes.

Touch screen panel adoption model
PDS400L/LC/LD, PDSG290LVR/C/D,
PDSK930LDP, PDSK1250LDP

03 The lineup of eco-friendly equipped oil fences "Leak-Guard"

Eco-friendly type with an integrated oil fence

In case fuel, oil or cooling water leaks on the frame, the oil fence prevents the leakage from flowing outside. It does not guarantee to prevent all oil leaks.

Built-in aftercooler drain tank allows to accumulate condensate. The tank is easily detachable for easy disposal of drain water.

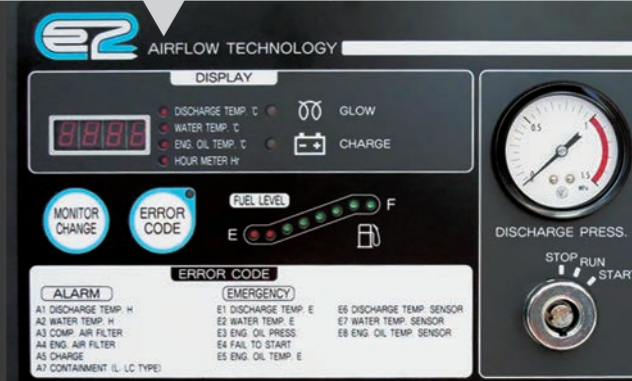

Model Lineup

We have a wide range of compressor models that you can choose from to suit your needs.

Series	Model [Free air delivery (CFM)]																					
Standard Pressure	65	80	100	130	140	185	265	400	655	670	750											
Enclosure	Box	■			■		■		■		■											
	Leak-Guard	■			■		■		■		■											
	Trailer	■			■		■		■		■		■									
High Pressure	F80	F100	F140	F210	F330	F530	F550	F750	F950	F1000	G290	G460	G900	G1400	H600	J850	J1100	J1550	K930	K1250		
Enclosure	Box	■			■		■		■		■		■		■		■		■		■	
	Leak-Guard	■			■		■		■		■		■		■		■		■		■	
	Trailer	■			■		■		■		■		■		■		■		■		■	
After-cooler	Standard Pressure						High Pressure															
	65	80	100	130	140	185	265	400	F100	F140	F210	F330	F750	F950	F1000	G290	G900	J850				
Enclosure	Box	■			■		■		■		■		■		■		■		■		■	
	Leak-Guard	■			■		■		■		■		■		■		■		■		■	
	Trailer	■			■		■		■		■		■		■		■		■		■	
Dry-air	Standard Pressure				High Pressure																	
	265	400	655	670	F330	F530	F550	G290														
Enclosure	Box	■		■		■		■														
	Leak-Guard	■		■		■		■														
	Trailer	■		■		■		■														

■ Model that complies with JPN Stage 3 exhaust gas regulations
■ Model that complies with JPN Stage 2 exhaust gas regulations

Oil fence

04

Variable pressure

Meeting the needs of variety of applications.



05

Availability for wide application

Integrated after-cooler / air-dryer models are also line up to suit a wide range of applications such as blasting, painting and pipeline regeneration.



06

A rotation stopper is equipped in the service valve

Rotation stoppers are equipped on the service valves to prevent loosening from the daily attaching and reattaching of air tools.

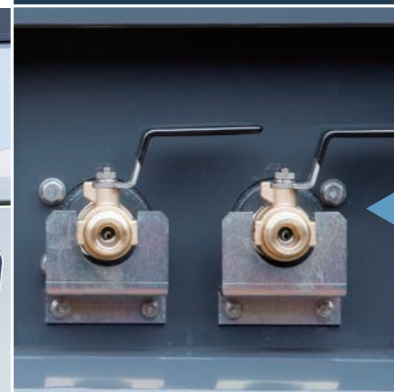

07

Rugged design

Strong and sturdy, the Box Type and Leak Guard are stackable for easy transport and storage.



08

Large wheels

We selected the most suitable wheel dimensions for effortless movement on-site.



Standard Pressure

PDS

Series

AIRMAN PDS series is the most popular compressor at construction sites. You can choose from a wide range of models from small to very large types to suits your needs.

The series features a sound-proof structure that is certified as a low-noise device, including ease of operation, monitor screens, and an emergency stop function. Also, the high-performance compressor has been field-proven to be durable and fuel efficient.

BOX type

Box-shaped and stackable, taking up very little storage space.

Leak-guard type

A structure designed to prevent the leakage of fuels, oils, coolants, and other fluids outside the machine.

Trailer type

Compressors with trailer are easy be moved on the construction site.



Leak-guard

Eco-friendly integrated oil fence for the first time in the industry.

In the event of fuel, oil and coolant water leakage, the leak guard can prevent outflow as much as possible to the outside of machine.

In addition to the standard model, numerous models featuring leak guard construction are available for high-pressure models, aftercooler models, and dry air models.

※ It does not guarantee to prevent all oil leaks.

※ Image is for illustration purposes.



Central pillarless structure

No interior, central pillar for easier access to maintenance items of some models.



Oil drain hose

Some models are equipped with a hose that makes it easy to discharge engine oil.



Standard PDS series



PDS65L-5C5



PDS100S-5C5



PDS140L-5C5

Item	Model	PDS65L-5C5	PDS80L-5C5	PDS80S-5C5	PDS100L-5C5	PDS100S-5C5	PDS130S-5C3	PDS140L-5C5
ENCLOSURE								
Box				●		●	●	
Leak-guard		●	●		●			●
Trailer								
COMPRESSOR								
Type		Rotary Twin Screw, Single-Stage, Oil-Cooled						
Free air delivery	m ³ /min[CFM]	1.84[65]	2.3[81]		2.8[99]		3.7[131]	4.0[141]
Rated operating pressure	MPa[kgf/cm ²][psi]	0.7[7.14][102]					0.69[7.0][100]	0.7[7.14][102]
Compressor oil capacity	L	7	8		9		15	14
Air outlet valve		3/4"×1, 3/8"×1		3/4"×2			3/4"×2, 3/8"×1	
ENGINE								
Brand		KUBOTA					YANMAR	
Model		D722-K3A	D902-K3A		D1105-K3B		3TNV88-BDHK	3TNV88-BDHK2
Type		Swirl Chamber					Direct-Injection	
Fuel injection/control method		Mechanical In-line Pump						
Emission stage		JPN Stage 3						
Rated output	kW[HP]/rpm	14.1[18.9]/3,600	17.0[22.8]/3,600		19.2[25.7]/3,400		26.9[36.1]/3,000	
Engine oil capacity	L	3.8	3.7		4.5		6.7	
Fuel tank capacity	L	18	33	25	33	28	70	69
Coolant capacity	L	4.0	3.7		4.1		4.5	
Battery		55B24R×1			85D26R×1			
DIMENSION & WEIGHT								
Length	mm	1,250	1,395	1,375	1,505	1,460	1,580	
Width	mm	700	770		800	770	890	
Height	mm	800	880	865	905	900	1,080	1,130
Dry (Operating) weight	kg	310 (340)	420 (460)	400 (435)	515 (555)	460 (500)	640 (720)	690 (770)
NOISE LEVEL								
Sound power level in decibels	dB	93			94	93	94	
Sound pressure level	dB (A)	67		66	67		66	

※ Sound pressure level is measured at 7m in 4 directions average.

※ In accordance with the IMDG Code, batteries may not be included with the machine, or the battery model may vary.

※ Specifications are subject to change without notice.



Standard **PDS** series



PDS185S-7C5



PDS185S-6C2



PDS265S-5C3

Item	Model	PDS185S-5C5	PDS185S-7C5	PDS185S-6C2	PDS265S-5C3	PDS265S-5B2	PDS265S-4B2
ENCLOSURE							
Box		●			●	●	
Leak-guard			●				
Trailer				●			●
COMPRESSOR							
Type		Rotary Twin Screw, Single-Stage, Oil-Cooled					
Free air delivery	m ³ /min[CFM]	5.2[184]			7.5[265]		
Rated operating pressure	MPa[kgf/cm ²][psi]	0.7[7.14][102]		0.69[7.0][100]			
Compressor oil capacity	L	15			30		
Air outlet valve		3/4"×3		3/4"×2	3/4"×4, 2"×1(OP)		
ENGINE							
Brand		YANMAR					
Model		4TNV88-BXDHKS R	4TNV88-BXDHKS I	KDP-4TNV98T	4TNV98T-NHK		
Type		Direct-Injection			Direct-Injection, Turbo-Charged		
Fuel injection/control method		Mechanical In-line Pump			Common Rail + ECU	Mechanical In-line Pump	
Emission stage		JPN Stage 3			JPN Stage 2		
Rated output	kW[HP]/rpm	34.9[46.8]/3,000		36.4[48.8]/3,000	61.2[82.1]/2,500		
Engine oil capacity	L	7.4			11	10.5	
Fuel tank capacity	L	90	92	90	115		
Coolant capacity	L	5.8			10		
Battery		85D26R×1			95D31R×1		
DIMENSION & WEIGHT							
Length	mm	1,850		2,960	2,050	2,970	
Width	mm	950			1,650	1,200	1,640
Height	mm	1,080	1,300	1,510	1,250	1,715	
Dry (Operating) weight	kg	755 (850)	825 (925)	860 (960)	1,150 (1,290)	1,360 (1,500)	
Tire size		-		175/80R13 97/95N×2	-	6.50-14 8PR×2	
NOISE LEVEL							
Sound power level in decibels	dB	94		99	98		
Sound pressure level	dB (A)	68		72	70	69	

※ Sound pressure level is measured at 7m in 4 directions average.
 ※ In accordance with the IMDG Code, batteries may not be included with the machine, or the battery model may vary.
 ※ Specifications are subject to change without notice.



PDS400L-5C5



PDS400S-6B6



PDS750S-4B1

Item	Model	PDS400L-5C5	PDS400L-5B5	PDS400S-6B6	PDS655S-4B2	PDS670S-4C5	PDS750S-4B1
ENCLOSURE							
Box							
Leak-guard		●	●				
Trailer				●	●	●	●
COMPRESSOR							
Type		Rotary Twin Screw, Single-Stage, Oil-Cooled					
Free air delivery	m ³ /min[CFM]	11.3[399]			17.9[632]	19.0[671]	21.2[749]
Rated operating pressure	MPa[kgf/cm ²][psi]	0.7[7.14][102]					
Compressor oil capacity	L	40			80	97	80
Air outlet valve		3/4"×3, 2"×1	3/4"×2, 2"×1		3/4"×2, 2"×1, 3/8"×1		
ENGINE							
Brand		KUBOTA			HINO	ISUZU	HINO
Model		V3800-DI-TI-K3B	V3800DI-TI-E2B		J08C-V	AI-4HK1X	J08C-UT
Type		Direct-Injection, Turbo-Charged, Intercooled			Direct-Injection	Direct-Injection, Turbo-Charged, Intercooled	Direct-Injection, Turbo-Charged
Fuel injection/control method		Common Rail + ECU	Mechanical In-line Pump			Common Rail + ECU	Mechanical In-line Pump
Emission stage		JPN Stage 3	JPN Stage 2	US Tier 2	JPN Stage 2	JPN Stage 3	JPN Stage 2
Rated output	kW[HP]/rpm	79.3[106.3]/2,600	75.2[100.8]/2,600		118[158.2]/2,500	118.6[159]/2,000	144.5[193.8]/2,100
Engine oil capacity	L	13			23	20.5	23
Fuel tank capacity	L	177			270	310	
Coolant capacity	L	15.6			29	26	29
Battery		130F51×1		120Ah×1	130F51×2		
DIMENSION & WEIGHT							
Length	mm	2,600		3,680	3,650	3,690	3,650
Width	mm	1,300			1,975	1,685	1,685
Height	mm	1,300			1,820	2,095	2,095
Dry (Operating) weight	kg	1,560 (1,760)	1,570 (1,770)	1,735 (1,935)	2,920 (3,260)	2,940 (3,310)	3,020 (3,370)
Tire size		-		6.50-R16 10PR×2	175/80R13 97/95N×4		
NOISE LEVEL							
Sound power level in decibels	dB	98	99		102	104	102
Sound pressure level	dB (A)	71	72	71	73	76	74

High Pressure PDSF/G/H/J/K Series

- DP**
Dual Pressure
[2 stage pressure switching]
- VR**
Variable Ratings
[Continuous variable control]



AIRMAN high-pressure compressors are the foundation of urban development. The core of the compressors, screw rotors are all developed in-house allowing us to achieve both incomparable power and variety in our products. This series is particularly effective for urban development projects including foundation work using down-the-hole or large-diameter boring techniques and spraying work to ensure the safety of slopes around a mountain road. Just a single one of our variable pressure type can handle multiple roles in a project, adjusting easily to the various pressure and air volume needs of your projects.

Leak-guard Variable Ratings [LVR]

Pressure setting that fits each site

You can freely choose any pressure within the range from 0.5MPa to 1.4MPa. Also, it has an integrated air boosting to automatically raise the engine rotation speed if the pressure drops.

Wide-range pressure control (VRS)

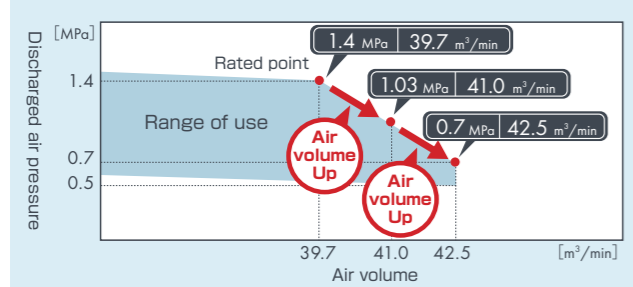

PDSG1400LVR

Pressure selection switch

Operator is able to change pressure value in 0.01 MPa increments on the display.



Range setting	Low	Middle	High
Initial setting [MPa]	0.7	1.03	1.4
Range setting [MPa]	0.65~0.75	0.76~1.08	1.09~1.4

※ Setting can be adjustable by 0.01MPa

PDSG1400LVR

High Pressure PDSF series



PDSF80S-5C5



PDSF140S-5C3



PDSF330DP-6B5

Item	Model	PDSF80S-5C5	PDSF100S-5C3	PDSF140S-5C3	PDSF210S-5C3	PDSF330LDP-5B5	PDSF330DP-6B5	
ENCLOSURE								
Box		●	●	●	●			
Leak-guard						● Dual Pressure		
Trailer							● Dual Pressure	
COMPRESSOR								
Type		Rotary Twin Screw, Single-Stage, Oil-Cooled						
Free air delivery	m³/min[CFM]	2.15[76]	2.8[99]	4.0[141]	6.0[212]	10.6[374]/9.3[328]		
Rated operating pressure	MPa[kgf/cm²][psi]	0.96[9.8][140]	1.03[10.5][150]			0.7[7.14][102]/1.03[10.5][150]		
Compressor oil capacity	L	9	15		30	40		
Air outlet valve		3/4"×2		3/4"×3	3/4"×2, 2"×1(OP)	3/4"×2, 2"×1		
ENGINE								
Brand		KUBOTA	YANMAR			KUBOTA		
Model		D1105-K3B	3TNV88-BDHK	4TNV88-BDHS	KDP-4TNV98T	V3800DI-TI-E2B		
Type		Swirl Chamber	Direct-Injection		Direct-Injection, Turbo-Charged	Direct-Injection, Turbo-Charged, Intercooled		
Fuel injection/control method		Mechanical In-line Pump			Common Rail + ECU	Mechanical In-line Pump		
Emission stage		JPN Stage 3				JPN Stage 2		
Rated output	kw[HP]/rpm	19.2[25.7]/3,400	26.9[36.1]/3,000	34.9[46.8]/3,000	61.2[82.1]/2,500	75.2[100.8]/2,600		
Engine oil capacity	L	4.5	6.7	7.4	11	13		
Fuel tank capacity	L	28	70	90	115	177	178	
Coolant capacity	L	4.1	4.5	5.8	10.0	15.6		
Battery		85D26R×1			95D31R×1	130F51×1		
DIMENSION & WEIGHT								
Length	mm	1,460	1,580	1,850	2,050	2,600	3,665	
Width	mm	770	890	950	1,200	1,300	1,975	
Height	mm	900	1,080		1,250	1,300	1,773	
Dry (Operating) weight	kg	460 (500)	640 (720)	740 (840)	1,150 (1,290)	1,570 (1,770)	1,780 (1,980)	
Tire size								6.50-14 8PR×2
NOISE LEVEL								
Sound power level in decibels	dB	92	94		98	99		
Sound pressure level	dB (A)	65			70			

※ Sound pressure level is measured at 7m in 4 directions average.
 ※ In accordance with the IMDG Code, batteries may not be included with the machine, or the battery model may vary.
 ※ Specifications are subject to change without notice.



High Pressure PDSF series



PDSF550S-4C5

PDSF750S-6C6

PDSF1000DP-4C5

Item	Model	PDSF530S -4B2	PDSF550S -4C5	PDSF750S -6C6	PDSF950S -4B4	PDSF1000DP -4C5
ENCLOSURE						
Box						
Leak-guard						
Trailer		●	● Dual Pressure	●	●	● Dual Pressure
COMPRESSOR						
Type		Rotary Twin Screw, Single-Stage, Oil-Cooled				
Free air delivery	m ³ /min[CFM]	14.3[505]	17.0[600]/15.6[551]	21.2[749]	26.9[950]	27.5[971]
Rated operating pressure	MPa[kgf/cm ²][psi]	1.05[10.7][152]	0.7[7.14][102]/ 1.03[10.5][150]	1.03[10.5][150]		0.7[7.14][102]/ 1.03[10.5][150]
Compressor oil capacity	L	80	97	62	100	110
Air outlet valve		3/4"×2, 2"×1, 3/8"×1		3/4"×1, 2"×2		3/4"×1, 2"×3
ENGINE						
Brand		HINO	ISUZU	DONGFENG CUMMINS		KOMATSU
Model		J08C-V	AI-4HK1X	QSB6.7-C260-III	6LTAA8.9-C360	SAA6D 125E-5
Type		Direct-Injection	Direct-Injection, Turbo-Charged, Intercooled			
Fuel injection/control method		Mechanical In-line Pump	Common Rail + ECU		Mechanical In-line Pump	Common Rail + ECU
Emission stage		JPN Stage 2	JPN Stage 3	GB III, EU Stage 3A	GB II	JPN Stage 3
Rated output	kW[HP]/rpm	118[158.2]/2,500	118.6[159]/2,000	181[242.7]/2,200	264[354]/2,200	247[331.2]/1,900
Engine oil capacity	L	23	20.5	15	21	41
Fuel tank capacity	L	270	310	300	540	600
Coolant capacity	L	29	26	30	57	64
Battery		130F51×2		120Ah×2	165Ah×2	170F51×2
DIMENSION & WEIGHT						
Length	mm	3,650	3,690	4,220	4,490	4,370
Width	mm	1,685	1,680	2,150	2,000	
Height	mm	2,095	2,145	2,130	2,430	2,290
Dry (Operating) weight	kg	2,960 (3,300)	2,980 (3,350)	3,040 (3,380)	4,420 (5,090)	4,990 (5,680)
Tire size		175/80R13 97/95N×4		8.25-16 16PR×2	7.50-16 14PR×4	
NOISE LEVEL						
Sound power level in decibels	dB	102	101	105	109	105
Sound pressure level	dB (A)	73	72	77	80	75

※ Sound pressure level is measured at 7m in 4 directions average.
 ※ In accordance with the IMDG Code, batteries may not be included with the machine, or the battery model may vary.
 ※ Specifications are subject to change without notice.

High Pressure PSDG series



PSDG460S-4B2

PSDG900DP-4C5

PSDG1400LVR-5C5

Item	Model	PSDG290LVR -5C5	PSDG460S -4B2	PSDG900DP -4C5	PSDG1400LDP -5C5	PSDG1400LVR -5C5
ENCLOSURE						
Box						
Leak-guard		● Variable pressure			● Dual Pressure	● Variable pressure
Trailer			●	● Dual Pressure		
COMPRESSOR						
Type		Rotary Twin Screw, Single-Stage, Oil-Cooled				
Free air delivery	m ³ /min[CFM]	9.6[339]~8.2[290]	12.5[441]	24.4[862]	39.7[1,402]	42.5[1,501]~39.7[1,402]
Rated operating pressure	MPa[kgf/cm ²][psi]	0.6[6.12][87] ~1.4[14.3][203]	1.27[13.0][185]	1.03[10.5][150]/1.4[14.3][203]		0.65[6.63][94] ~1.4[14.3][203]
Compressor oil capacity	L	38	80	95	200	
Air outlet valve		3/4"×3, 2"×1	3/4"×2, 2"×1, 3/8"×1	3/4"×1, 2 1/2"×1	3/4"×1, 3"×1	
ENGINE						
Brand		KOBOTA	HINO	KOMATSU		
Model		V3800DI-TI-K3B	J08C-V	SAA6D 125E-5-A	SAA6D 140E-5-B	
Type		Direct-Injection, Turbo-Charged, Intercooled	Direct-Injection	Direct-Injection, Turbo-Charged, Intercooled		
Fuel injection/control method		Common Rail + ECU	Mechanical In-line Pump	Common Rail + ECU		
Emission stage		JPN Stage 3	JPN Stage 2	JPN Stage 3		
Rated output	kW[HP]/rpm	79.3[106.3]/2,600	118[158.2]/2,500	247[331.2]/1,900	398[533.7]/2,000	
Engine oil capacity	L	13	23	41	61	
Fuel tank capacity	L	177	270	600	780	
Coolant capacity	L	15.6	29	64	68	
Battery		130F51×1	130F51×2	170F51×2	225H52×2	
DIMENSION & WEIGHT						
Length	mm	2,600	3,650	4,370	4,750	
Width	mm	1,300	1,685	2,000	1,950	
Height	mm	1,300	2,135	2,290	2,050	
Dry (Operating) weight	kg	1,590 (1,790)	2,970 (3,310)	4,950 (5,620)	6,610 (7,530)	
Tire size		-	6.50-14 8PR×4	7.50-16 14PR×4	-	
NOISE LEVEL						
Sound power level in decibels	dB	99	102	103	104	
Sound pressure level	dB (A)	70	73		74	

High Pressure PDSH/J series



PDSH600S-6C6

PDSJ850DP-4C5

PDSJ1100DP-4C5

Item	Model	PDSH600S -6C6	PDSJ850DP -4C5	PDSJ1100DP -4C5
ENCLOSURE				
Box				
Leak-guard				
Trailer		●	● Dual Pressure	● Dual Pressure
COMPRESSOR				
Type		Rotary Twin Screw, Single-Stage, Oil-Cooled	Rotary Twin Screw, Two-Stage, Oil-Cooled	
Free air delivery	m ³ /min[CFM]	17.0[600]	24.1[851]	29.7[1,049]
Rated operating pressure	MPa[kgf/cm ²][psi]	1.7[17.3][247]	1.7[17.3][247]/2.0[20.4][290]	
Compressor oil capacity	L	63	98	
Air outlet valve		3/4"×2, 2"×1	3/4"×1, 2"×1	
ENGINE				
Brand		DONGFENG CUMMINS	KOMATSU	
Model		QSB6.7-C260-III	SAA6D 125E-5-A	SAA6D 125E-5-C
Type		Direct-Injection, Turbo-Charged, Intercooled		
Fuel injection/control method		Common Rail + ECU		
Emission stage		GB III, EU Stage 3A	JPN Stage 3	
Rated output	kW[HP]/rpm	181[242.7]/2,200	247[331.2]/1,900	282.9[379.4]/2,100
Engine oil capacity	L	15	41	
Fuel tank capacity	L	300	600	700
Coolant capacity	L	30	64	
Battery		120Ah×2	170F51×2	
DIMENSION & WEIGHT				
Length	mm	4,220	4,370	
Width	mm	2,150	2,000	
Height	mm	2,130	2,290	
Dry (Operating) weight	kg	3,040 (3,380)	5,270 (5,940)	5,520 (6,270)
Tire size		8.25-16 16PR×2	7.50-16 14PR×4	
NOISE LEVEL				
Sound power level in decibels	dB	104	102	
Sound pressure level	dB (A)	76	73	78

※ Sound pressure level is measured at 7m in 4 directions average.
 ※ In accordance with the IMDG Code, batteries may not be included with the machine, or the battery model may vary.
 ※ Specifications are subject to change without notice.

High Pressure PDSJ/K series



PDSJ1100/K930LDP-5C5

PDSJ1550DP-4C6

PDSK1250LDP-5C5

Item	Model	PDSJ1100/K930LDP -5C5	PDSK930DP -4C5	PDSJ1550DP -4C6	PDSK1250LDP -5C5
ENCLOSURE					
Box					
Leak-guard		● Dual Pressure			● Dual Pressure
Trailer			● Dual Pressure	● Dual Pressure	
COMPRESSOR					
Type		Rotary Twin Screw, Two-Stage, Oil-Cooled			
Free air delivery	m ³ /min[CFM]	29.7[1,049]/25.5[901]	25.5[901]	43.9[1,550]/42.5[1,501]	37.0[1,307]~35.4[1,250]
Rated operating pressure	MPa[kgf/cm ²][psi]	2.0[20.4][290]/2.5[25.5][363]		1.7[17.3][247] /2.0[20.4][290]	2.0[20.4][290] /2.5[25.5][363]
Compressor oil capacity	L	98		150	165
Air outlet valve		3/4"×1, 2"×1			3/4"×1, 3"×1
ENGINE					
Brand		KOMATSU			
Model		SAA6D 125E-5-C		SAA6D 140E-5-B	
Type		Direct-Injection, Turbo-Charged, Intercooled			
Fuel injection/control method		Common Rail + ECU			
Emission stage		JPN Stage 3			
Rated output	kW[HP]/rpm	282.9[379.4]/2,100		398[533.7]/2,000	
Engine oil capacity	L	41		61	
Fuel tank capacity	L	710	700	902	880
Coolant capacity	L	69	64	75	
Battery		170F51×2		225H52×2	
DIMENSION & WEIGHT					
Length	mm	4,300	4,370	4,900	4,850
Width	mm	1,850	2,000	2,100	2,150
Height	mm	1,900	2,290	2,500	2,100
Dry (Operating) weight	kg	5,080 (5,850)	5,520 (6,270)	7,510 (8,500)	7,250 (8,250)
Tire size		-	7.50-16 14PR×4	7.00-15 14PR (I) ×4	-
NOISE LEVEL					
Sound power level in decibels	dB	102	103	104	
Sound pressure level	dB (A)	73		74	

After-Cooler **PDS-C** Series

Adiabatic expansion within a high-load device such as a concrete breaker, rapidly cools compressed air. As a result, water droplets can scatter from the breaker's exhaust or can freeze in some areas during winter. But since the integrated After-Cooler cools, condenses and eliminates moisture from compressed air, the discharged air from PDS-C contains only a small amount of water. This functionality proves its true value in chipping and sandblasting operations.

All are caused by moisture within the compressed air!



As the After-cooler cools and condenses the moisture in the compressed air, the discharged air contains only a small amount of water

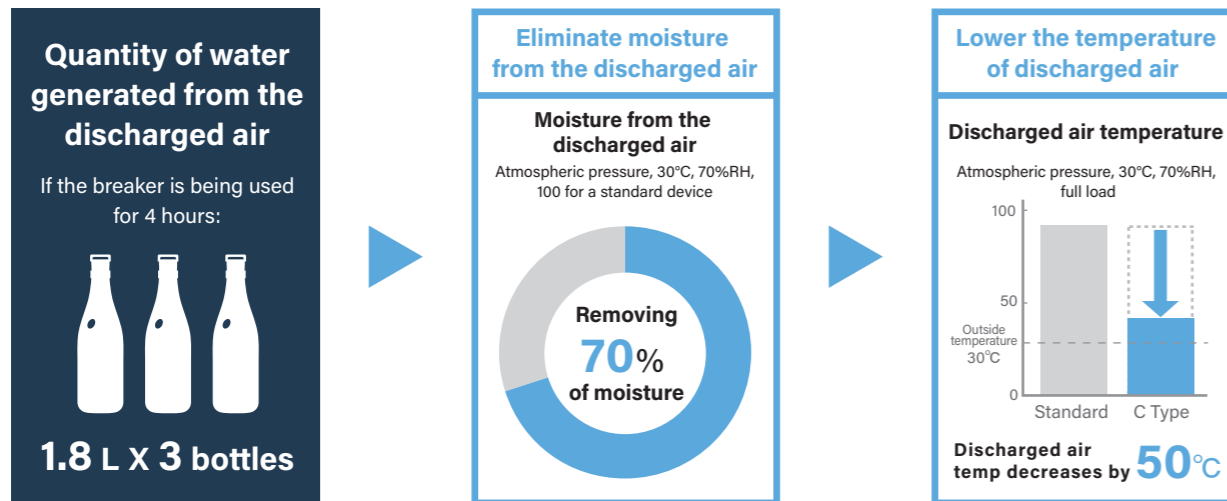

After-Cooler **PDS-C** series



PDS65LC-5C5

PDS80LC-5C5

PDS100SC-5C5

Item	Model	PDS65LC-5C5	PDS80LC-5C5	PDS80SC-5C5	PDS100LC-5C5	PDS100SC-5C5
ENCLOSURE						
Box				●		●
Leak-guard		●	●		●	
Trailer						
COMPRESSOR						
Type		Rotary Twin Screw, Single-Stage, Oil-Cooled				
Free air delivery	m ³ /min[CFM]	1.84[65]	2.3[81]		2.8[99]	
Rated operating pressure	MPa[kgf/cm ²][psi]	0.7[7.14][102]				
Compressor oil capacity	L	7	8		9	
Discharge air temperature	°C	Atmospheric Temperature + 20				
Air outlet valve		3/4"×1, 3/8"×1		3/4"×2		
ENGINE						
Brand		KUBOTA				
Model		D722-K3A	D902-K3A		D1105-K3B	
Type		Swirl Chamber				
Fuel injection/control method		Mechanical In-line Pump				
Emission stage		JPN Stage 3				
Rated output	kW[HP]/rpm	14.1[18.9]/3,600	17.0[22.8]/3,600		19.2[25.7]/3,400	
Engine oil capacity	L	3.8	3.7		4.5	
Fuel tank capacity	L	18	33	25	33	28
Coolant capacity	L	4.0	3.7		4.1	
Battery		55B24R×1			85D26R×1	
DIMENSION & WEIGHT						
Length	mm	1,250	1,395	1,375	1,505	1,460
Width	mm	700	770		800	770
Height	mm	800	880	865	905	900
Dry (Operating) weight	kg	315 (345)	430 (470)	405 (440)	525 (565)	470 (510)
NOISE LEVEL						
Sound power level in decibels	dB	93			95	93
Sound pressure level	dB (A)	67		66	67	

※ Sound pressure level is measured at 7m in 4 directions average.
 ※ In accordance with the IMDG Code, batteries may not be included with the machine, or the battery model may vary.
 ※ Specifications are subject to change without notice.



After-Cooler **PDS-C** series



PDS130SC-5C3



PDS140LC-5C5



PDS185SC-5C5



PDS265SC-5C3



PDS400LC-5B5



PDS400SC-6B5

Item	Model	PDS130SC -5C3	PDS140LC -5C5	PDS185SC -5C5	PDS185SC -7C5
ENCLOSURE					
Box		●		●	
Leak-guard			●		● Oil Fence
Trailer					
COMPRESSOR					
Type		Rotary Twin Screw, Single-Stage, Oil-Cooled			
Free air delivery	m ³ /min[CFM]	3.7[131]	4.0[141]	5.2[184]	
Rated operating pressure	MPa[kgf/cm ²][psi]	0.69[7.0][100]	0.7[7.14][102]		
Compressor oil capacity	L	15	14	15	
Discharge air temperature	°C	Atmospheric Temperature + 20			
Air outlet valve		3/4"×2	3/4"×2, 3/8"×1	3/4"×3	
ENGINE					
Brand		YANMAR			
Model		3TNV88-BDHK	3TNV88-BDHK2	4TNV88-BXDHKSR	
Type		Direct-Injection			
Fuel injection/control method		Mechanical In-line Pump			
Emission stage		JPN Stage 3			
Rated output	kW[HP]/rpm	26.9[36.1]/3,000		34.9[46.8]/3,000	
Engine oil capacity	L	6.7		7.4	
Fuel tank capacity	L	70	69	90	92
Coolant capacity	L	4.5		5.8	
Battery		85D26R×1			
DIMENSION & WEIGHT					
Length	mm	1,580		1,850	
Width	mm	890		950	
Height	kg	1,080	1,130	1,080	1,300
Dry (Operating) weight		650 (730)	700 (780)	765 (860)	835 (935)
NOISE LEVEL					
Sound power level in decibels	dB	94			
Sound pressure level	dB (A)	66		68	

※ Sound pressure level is measured at 7m in 4 directions average.
 ※ In accordance with the IMDG Code, batteries may not be included with the machine, or the battery model may vary.
 ※ Specifications are subject to change without notice.

Item	Model	PDS265SC -5C3	PDS265SC -5B2	PDS265SC -4B2	PDS400LC -5C5	PDS400LC -5B5	PDS400SC -6B5
ENCLOSURE							
Box		●	●				
Leak-guard					●	●	
Trailer				●			●
COMPRESSOR							
Type		Rotary Twin Screw, Single-Stage, Oil-Cooled					
Free air delivery	m ³ /min[CFM]	7.5[265]			11.3[399]		
Rated operating pressure	MPa[kgf/cm ²][psi]	0.69[7.0][100]			0.7[7.14][102]		
Compressor oil capacity	L	30			40		
Discharge air temperature	°C	Atmospheric Temperature + 20					
Air outlet valve		3/4"×4, 2"×1(OP)			3/4"×3, 2"×1	3/4"×2, 2"×1	
ENGINE							
Brand		YANMAR			KUBOTA		
Model		KDP-4TNV98T	4TNV98T-NHK		V3800-DI-TI-K3B	V3800DI-TI-E2B	
Type		Direct-Injection, Turbo-Charged			Direct-Injection, Turbo-Charged, Intercooled		
Fuel injection/control method		Common Rail + ECU	Mechanical In-line Pump		Common Rail + ECU	Mechanical In-line Pump	
Emission stage		JPN Stage 3	JPN Stage 2		JPN Stage 3	JPN Stage 2	
Rated output	kW[HP]/rpm	61.2[82.1]/2,500			79.3[106.3]/2,600	75.2[100.8]/2,600	
Engine oil capacity	L	11	10.5		13		
Fuel tank capacity	L	115			177	178	
Coolant capacity	L	10			15.6		
Battery		95D31R×1			130F51×1		
DIMENSION & WEIGHT							
Length	mm	2,050	2,970		2,600	3,665	
Width	mm	1,200	1,640		1,300	1,975	
Height	mm	1,250	1,715		1,300	1,773	
Dry (Operating) weight	kg	1,170 (1,310)	1,380 (1,520)		1,610 (1,810)	1,820 (2,020)	
Tire size		-	145/80R12.86/84N×2		-	6.50-14 8PR×2	
NOISE LEVEL							
Sound power level in decibels	dB	98			99		
Sound pressure level	dB (A)	70	69	71	72	71	

After-Cooler **PDSF-C** series



PDSF100SC-5C3



PDSF140SC-5C3



PDSF330LDPC-5B5

Item	Model	PDSF100SC-5C3	PDSF140SC-5C3	PDSF210SC-5C3	PDSF330LDPC-5B5	PDSF330DPC-6B5
ENCLOSURE						
Box		●	●	●		
Leak-guard					● Dual Pressure	
Trailer						● Dual Pressure
COMPRESSOR						
Type		Rotary Twin Screw, Single-Stage, Oil-Cooled				
Free air delivery	m ³ /min[CFM]	2.8[99]	4.0[141]	6.0[212]	10.6[374]/9.3[328]	
Rated operating pressure	MPa[kgf/cm ²][psi]	1.03[10.5][150]			0.7[7.14][102]/1.03[10.5][150]	
Compressor oil capacity	L	15		30	40	
Discharge air temperature	°C	Atmospheric Temperature + 20				
Air outlet valve		3/4"×2	3/4"×3	3/4"×4, 2"×1(OP)	3/4"×2, 2"×1	
ENGINE						
Brand		YANMAR			KUBOTA	
Model		3TNV88-BDHK	4TNV88-BDHKS	KDP-4TNV98T	V3800DI-TI-E2B	
Type		Direct-Injection		Direct-Injection, Turbo-Charged	Direct-Injection, Turbo-Charged, Intercooled	
Fuel injection/control method		Mechanical In-line Pump		Common Rail + ECU	Mechanical In-line Pump	
Emission stage		JPN Stage 3			JPN Stage 2	
Rated output	kW[HP]/rpm	26.9[36.1]/3,000	34.9[46.8]/3,000	61.2[82.1]/2,500	75.2[100.8]/2,600	
Engine oil capacity	L	6.7	7.4	11	13	
Fuel tank capacity	L	70	90	115	177	178
Coolant capacity	L	4.5	5.9	10.0	15.6	
Battery		85D26R×1		95D31R×1	130F51×1	
DIMENSION & WEIGHT						
Length	mm	1,580	1,850	2,050	2,600	3,665
Width	mm	890	950	1,200	1,300	1,975
Height	mm	1,080		1,250	1,300	1,773
Dry (Operating) weight	kg	650 (730)	750 (850)	1,170 (1,310)	1,610 (1,810)	1,820 (2,020)
Tire size						6.50-14 8PR×2
NOISE LEVEL						
Sound power level in decibels	dB	94		98	99	
Sound pressure level	dB (A)	65			70	

※ Sound pressure level is measured at 7m in 4 directions average.
 ※ In accordance with the IMDG Code, batteries may not be included with the machine, or the battery model may vary.
 ※ Specifications are subject to change without notice.

After-Cooler **PDSF/G/J-C** series



PDSF950SC-4B4



PDSG290LVRC-5C5



PDSG900DPC-4C5

Item	Model	PDSF750SC-6C6	PDSF950SC-4B4	PDSF1000DPC-4C5	PDSG290LVRC-5C5	PDSG900DPC-4C5	PDSJ850DPC-4C5
ENCLOSURE							
Box							
Leak-guard					● Variable pressure		
Trailer		●	●	● Dual Pressure		● Dual Pressure	● Dual Pressure
COMPRESSOR							
Type		Rotary Twin Screw, Single-Stage, Oil-Cooled					Rotary Twin Screw, Two-Stage, Oil-Cooled
Free air delivery	m ³ /min[CFM]	21.2[749]	26.9[950]	27.5[971]	9.6[339]~8.2[290]	24.4[862]	24.1[851]
Rated operating pressure	MPa[kgf/cm ²][psi]	1.03[10.5][150]		0.7[7.14][102]/1.03[10.5][150]	0.6[6.12][87]~1.4[14.3][203]	1.03[10.5][150]/1.4[14.3][203]	1.7[17.3][247]/2.0[20.4][290]
Compressor oil capacity	L	62	100	110	38	95	98
Discharge air temperature	°C	Atmospheric Temperature + 20					
Air outlet valve		3/4"×1, 2"×2		3/4"×1, 2"×3	3/4"×3, 2"×1	3/4"×1, 2 1/2"×1	3/4"×1, 2"×1
ENGINE							
Brand		DONGFENG CUMMINS		KOMATSU	KOBOTA	KOMATSU	
Model		QSB6.7-C260-III	6LTA8.9-C360	SAA6D 125E-5	V3800DI-TI-K3B	SAA6D 125E-5-A	
Type		Direct-Injection, Turbo-Charged, Intercooled					
Fuel injection/control method		Common Rail + ECU	Mechanical In-line Pump	Common Rail + ECU			
Emission stage		GBIII, EU Stage 3A	GBII	JPN Stage 3			
Rated output	kW[HP]/rpm	181[242.7]/2,200	264[354]/2,200	247[331.2]/1,900	79.3[106.3]/2,600	247[331.2]/1,900	
Engine oil capacity	L	15	21	41	13	41	
Fuel tank capacity	L	300	540	600	177	600	
Coolant capacity	L	30	57	64	15.6	64	
Battery		120Ah×2	165Ah×2	170F51×2	130F51×1	170F51×2	
DIMENSION & WEIGHT							
Length	mm	4,220	4,490	4,370	2,600	4,370	
Width	mm	2,150	2,000		1,300	2,000	
Height	mm	2,130	2,430	2,290	1,300	2,290	
Dry (Operating) weight	kg	3,100 (3,440)	4,520 (5,190)	5,100 (5,790)	1,640 (1,840)	5,050 (5,720)	5,350 (6,030)
Tire size		8.25-16 16PR×2	7.50-16 14PR×4		-	7.50-16 14PR×4	
NOISE LEVEL							
Sound power level in decibels	dB	105	109	105	99	103	
Sound pressure level	dB (A)	77	80	75	70	73	

Dry-Air PDS-D Series

AIRMAN PDS-D is a series of compressors that supplies dry air with low humidity. It supplies dry service air at atmospheric temperature +40°C and contains numerous devices such as aftercooler to cool the compressed air, auto drain to discharge collected water, and afterwarmer to lower the humidity of the compressed air. Because the machine frees compressed air from water in humid conditions like a rainy day or even a rainy season, this series is particularly suitable for duct recovering, painting, sandblasting, and factory air. *Does not supply oil-free air.

Switchable between dry air (high temperature), after-cooled air (low temperature) and normal air

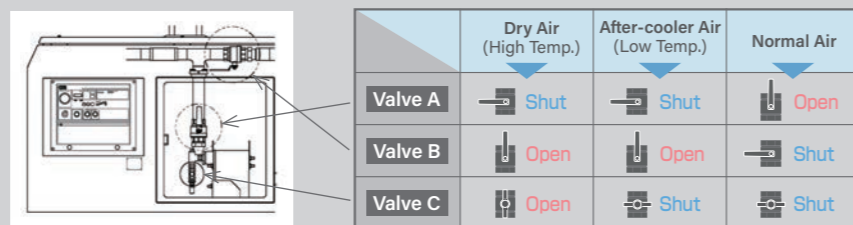

※After-cooler air of applications: intake air to separated dryer

Dry air production

After the removal of oil by the oil separator, the compressed air is cooled significantly by the aftercooler.

As the compressed air is cooled, a saturated vapor (vapor that cannot be absorbed in the compressed air) is changed into small water drops and then drained.

The dehydrated compressed air is heated by the afterwarmer, reusing the hot water from the engine. The heat makes the compressed air less humid, transforming it into dry air.

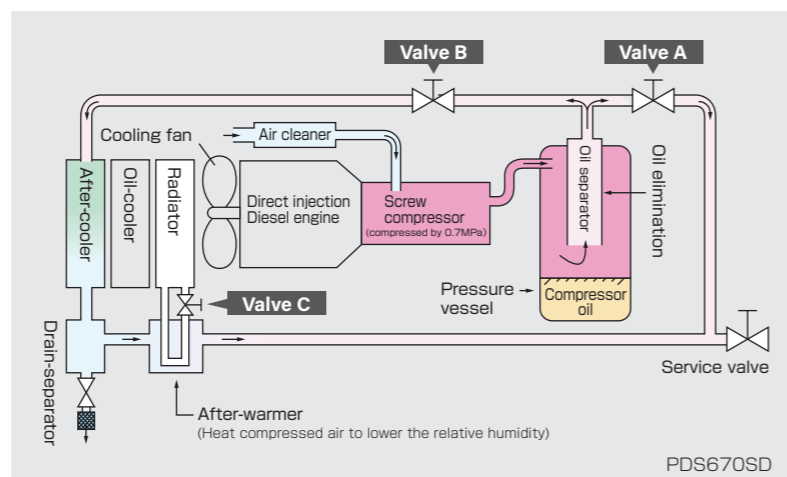

Dry-Air PDS-D series



PDS265SD-5C3



PDS400LD-5B5



PDS670SD-4C5

Item	Model	PDS265SD-5C3	PDS400LD-5C5	PDS400LD-5B5	PDS655SD-4B2	PDS670SD-4C5
ENCLOSURE						
Box		●				
Leak-guard			●	●		
Trailer					●	●
COMPRESSOR						
Type		Rotary Twin Screw, Single-Stage, Oil-Cooled				
Free air delivery	m ³ /min[CFM]	7.5[265]	11.3[399]		17.9[632]	19.0[671]
Rated operating pressure	MPa[kgf/cm ²][psi]	0.69[7.0][100]	0.7[7.14][102]			
Compressor oil capacity	L	30	40		80	97
Discharge air temperature	°C	Atmospheric Temperature + 40				
Air outlet valve		3/4"×4, 2"×1 (OP)	3/4"×3, 2"×1	3/4"×2, 2"×1	3/4"×2, 2"×1, 3/8"×1	
ENGINE						
Brand		YANMAR	KUBOTA		HINO	ISUZU
Model		KDP-4TNV98T	V3800DI-DI-TI-K3B	V3800DI-TI-E2B	J08C-V	AI-4HK1X
Type		Direct-Injection, Turbo-Charged	Direct-Injection, Turbo-Charged, Intercooled		Direct-Injection	Direct-Injection, Turbo-Charged, Intercooled
Fuel injection/control method		Common rail + ECU		Mechanical In-line Pump		Common Rail + ECU
Emission stage		JPN Stage 3		JPN Stage 2		JPN Stage 3
Rated output	kW[HP]/rpm	61.2[82.1]/2,500	79.3[106.3]/2,600	75.2[100.8]/2,600	118[158.2]/2,500	118.6[159]/2,000
Engine oil capacity	L	11	13		23	20.5
Fuel tank capacity	L	115	177		270	310
Coolant capacity	L	10	21		35	36
Battery		95D31R×1	130F51×1		130F51×2	
DIMENSION & WEIGHT						
Length	mm	2,175	2,600		3,650	3,690
Width	mm	1,200	1,300		1,685	1,680
Height	mm	1,250	1,300		2,095	2,145
Dry (Operating) weight	kg	1,210 (1,350)	1,660 (1,860)	1,640 (1,840)	3,190 (3,530)	3,050 (3,430)
Tire size				175/80R13 97/95N×4		
NOISE LEVEL						
Sound power level in decibels	dB	98	99		102	104
Sound pressure level	dB (A)	70	71	72	73	76

※ Sound pressure level is measured at 7m in 4 directions average.
 ※ In accordance with the IMDG Code, batteries may not be included with the machine, or the battery model may vary.
 ※ Specifications are subject to change without notice.



Dry-Air **PDSF/G-D** series



PDSF330LDPD-5B5

PDSF550SD-4C5

PDSG290LVRD-5C5

Item	Model	PDSF330LDPD -5B5	PDSF530SD -4B2	PDSF550SD -4C5	PDSG290LVRD -5C5
ENCLOSURE					
Box					
Leak-guard		● Dual Pressure			● Variable pressure
Trailer			●	● Dual Pressure	
COMPRESSOR					
Type		Rotary Twin Screw, Single-Stage, Oil-Cooled			
Free air delivery	m ³ /min[CFM]	10.6[374]/9.3[328]	15.0[530]	17.0[600]/15.6[551]	9.6[339]~8.2[290]
Rated operating pressure	MPa[kgf/cm ²][psi]	0.7[7.14][102]/ 1.03[10.5][150]	1.05[10.7][152]	0.7[7.14][102]/ 1.03[10.5][150]	0.6[6.12][87] ~1.4[14.3][203]
Compressor oil capacity	L	40	80	97	38
Discharge air temperature	°C	Atmospheric Temperature + 40			
Air outlet valve		3/4"×2, 2"×1	3/4"×2, 2"×1, 3/8"×1		3/4"×3, 2"×1
ENGINE					
Brand		KUBOTA	HINO	ISUZU	KOBOTA
Model		V3800DI-TI-E2B	J08C-V	AI-4HK1X	V3800DI-TI-K3B
Type		Direct-Injection, Turbo-Charged, Intercooled	Direct-Injection	Direct-Injection, Turbo-Charged, Intercooled	
Fuel injection/control method		Mechanical In-line Pump		Common Rail + ECU	
Emission stage		JPN Stage 2		JPN Stage 3	
Rated output	kW[HP]/rpm	75.2[100.8]/2,600	118[158.2]/2,500	118.6[159]/2,000	79.3[106.3]/2,600
Engine oil capacity	L	13	23	20.5	13
Fuel tank capacity	L	177	270	310	177
Coolant capacity	L	21	29	36	21
Battery		130F51×1	130F51×2		130F51×1
DIMENSION & WEIGHT					
Length	mm	2,600	3,650	3,690	2,600
Width	mm	1,300	1,685	1,680	1,300
Height	mm	1,300	2,095	2,145	1,300
Dry (Operating) weight	kg	1,640 (1,840)	3,190 (3,530)	3,090 (3,470)	1,690 (1,890)
Tire size		-	175/80R13 97/95N×4		-
NOISE LEVEL					
Sound power level in decibels	dB	99	102	101	99
Sound pressure level	dB (A)	70	73	72	70

※ Sound pressure level is measured at 7m in 4 directions average.
 ※ In accordance with the IMDG Code, batteries may not be included with the machine, or the battery model may vary.
 ※ Specifications are subject to change without notice.

AIRMAN's Journey in Portable Compressor Innovation

1938 ● The predecessor of our company, **Jizodou Foundry Co., Ltd.**, was established in Japan and began manufacturing reciprocating compressor parts.

1939 ● Launched the finished compressor series **VTS, HSD, HST, and HTTD**. In this year, the company officially entered the market as a compressor manufacturer. The company's name was changed to **Hokuetsu Kogyo Co., Ltd.**

1940 ● **Japan's first** air-cooled single-acting two-stage compressor, the "**AW Series**," which requires no cooling water, has been developed.

1942 ● The motor-driven reciprocating (piston) portable compressor was developed.

1944 ● Launch of diesel engine-driven portable compressor

1947 ● These portable compressors were supplied to Japan National Railways, government construction departments and military.

1948 ● **Farst export**
Exported 200-horsepower and 300-horsepower horizontal air compressors for mining use to the Korean government.

1950 ● **Japan's first** high-speed diesel engine compressors.

1952 ● The **AIRMAN** brand name and logo were created. With this brand, Hokuetsu Co., Ltd.'s technological innovation spread worldwide.

1951 ● The **AM60, 105, 130, 210, 315, 420, 500, and 600** models, equipped with air-cooled, two-stage reciprocating compressors, were released one after another.

1954 ● The **AM Series** played an active role at construction sites and military facilities, establishing "**AIRMAN**" as a well-known name synonymous with compressors.

1955 ● **Japan's first** engine-driven rotary (vane-type) portable compressors, marking the beginning of the rotary compressor era.

1963 ● Launched the **AMS Series** of engine-driven screw portable compressors.

1970 ● **Japan's largest** Developed the **AIRMAN** profile, a proprietary screw rotor profile. Launched some of **Japan's largest** portable screw compressors, such as the **AMS750, 900, and 1200**.

1971 ● Announced the new engine-driven rotary (vane) portable compressor **PDR** series.

1977 ● Achieved sales of **100,000** portable compressors.

1980 ● Announced the new engine-driven screw portable compressor **PDS** series.

1982 ● The **PDS** series received the "**Excellent Energy-Saving Equipment Award**" from the Japan Machinery Federation.

1986 ● Sequentially release the high-pressure portable compressors series **PDSE, F, G, H, J, and K**.



SAFETY

- Do not use compressed air for breathing, such as in pneumatic methods or diving operations, or for exhalation system equipment that directly inhales air.
- Operate safely in accordance with operation manual.
- To prevent trouble and accidents, perform daily and preventive maintenance checks without fail.